

ITEM NO.	PART NUMBER	DESCRIPTION	QTY.
1	171012	1200L HORIZONTAL TRANSPORT TANK	1
2	198510	1200-1500 SKID FRAME W/ PUMP PLATE	1

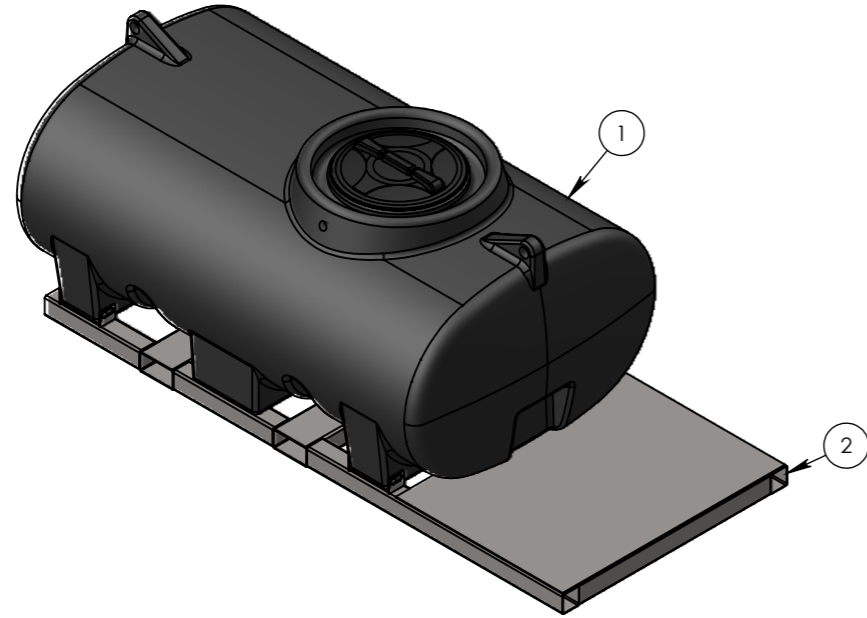

LEFT ISO VIEW

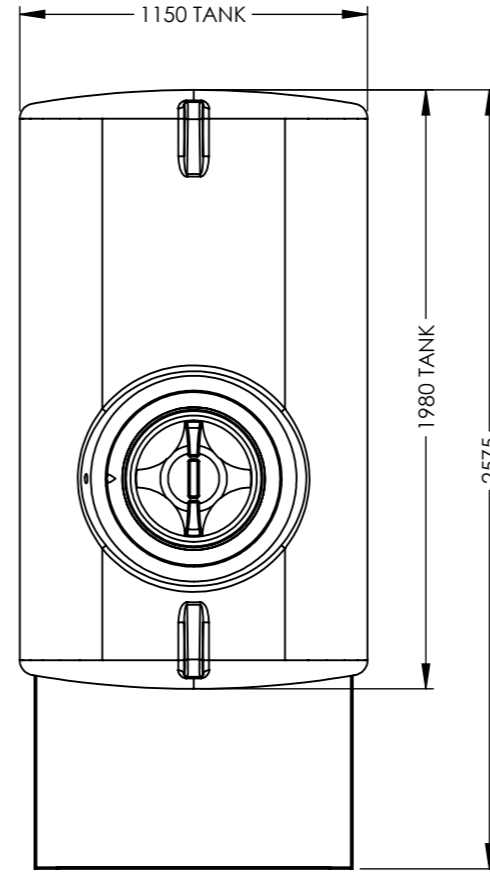

PLAN VIEW

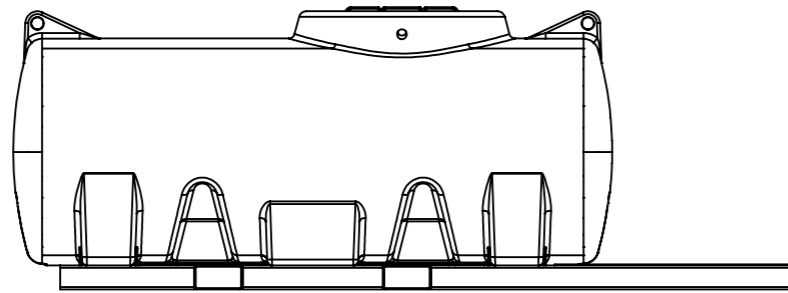

LEFT VIEW

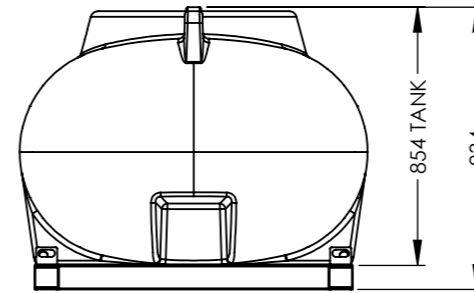

FRONT VIEW

DESIGN DATA

DESIGN PRESSURE: ATMOSPHERIC	MAXIMUM CAPACITY (LTRS):
DESIGN TEMPERATURE: 40°C	WORKING CAPACITY (LTRS):
WORKING PRESSURE: ATMOSPHERIC	APPROX. WEIGHT FULL (KGS):
WORKING TEMPERATURE: 40°C	APPROX. WEIGHT EMPTY (KGS):
MOULDED LIFTING LUGS: 4 - 0°, 90°, 180° & 270°	
METHOD OF SUPPORT: FIRM, FLAT, FULLY SUPPORTING BASE OF CONCRETE OR OTHER SUITABLE MATEREAL	

MATERIAL DATA

MATERIALS OF CONSTRUCTION:
 MATRIX REVOLVE N-307. REVOLVE IS A HIGH DENSITY (0.939 g/cm3), LOW MELT (3.5 g/ 10 min) HEXENE POLYETHYLENE GRADE FOR ROTOMOULDING. THE GRADE IS FULLY PROTECTED AGAINST THERMAL AND LIGHT DEGRADATION: N-307 IS UV10 STABILISED.

INSPECTION AND TESTING

WORKS TEST: ALL TANKS ARE THICKNESS TESTED BY ULTRASOUND AFTER DEMOULD IN ADDITION AIR SUPPORTED LEAK TEST ARE CARRIED OUT ON FLANGE LINES.

NOTE SECTION

	NAME	SIGNATURE	DATE
DRAWN	LC	L.Crane	23/08/2022
CHECKED			

UNLESS OTHERWISE SPECIFIED:
 DIMENSIONS ARE IN MILLIMETERS
 SURFACE FINISH: MDPE
 TOLERANCES: ±3%

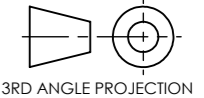

DO NOT SCALE DRAWING

REVISION: -

ENDURAMAXX®
 FLUID MANAGEMENT INNOVATION

DWG TITLE:
 1200L HORIZONTAL TANK - SKID FRAME & PUMP PLATE

DWG NO: 171012-1200L-TRANSPORT-SKID-PP A3

SCALE: 1:25 SHEET 1 OF 1